

Customer Information Sheet

DRAWING No.: H2159-XX

IF IN DOUBT - ASK

©

NOT TO SCALE

THIRD ANGLE PROJECTION

ALL DIMENSIONS IN mm

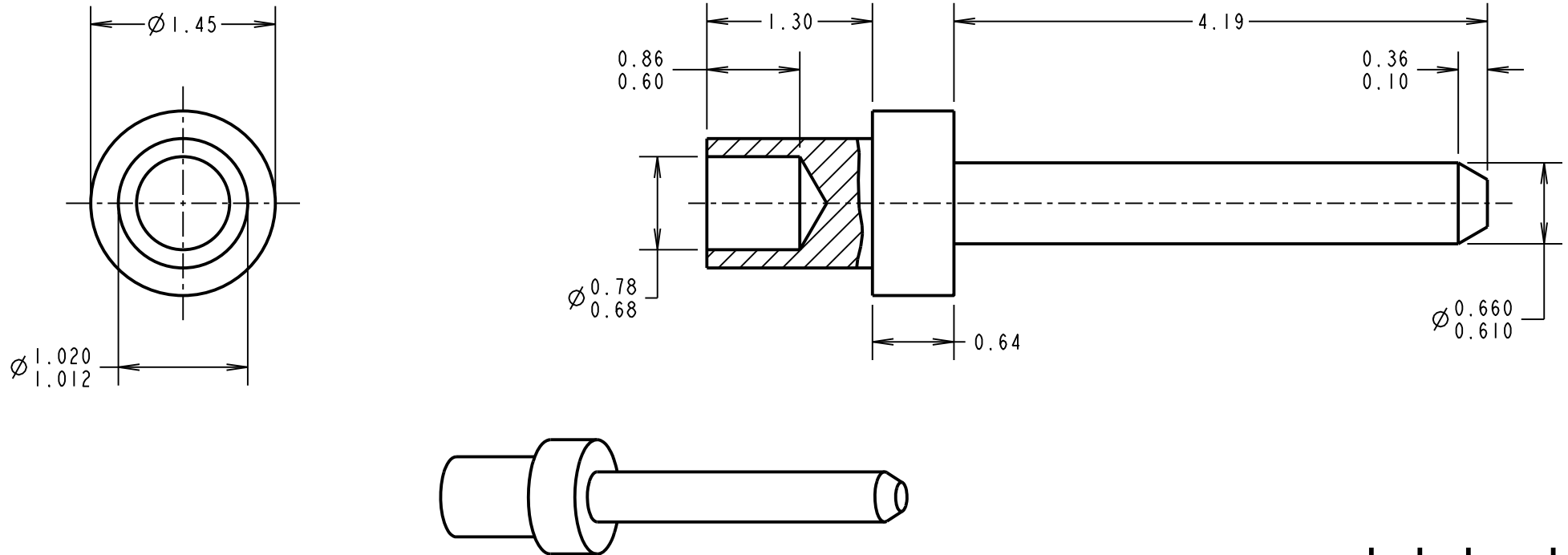

- NOTES:
1. UNLESS OTHERWISE STATED, TOLERANCES = ± 0.13
 2. RECOMMENDED HOLE SIZE = $\varnothing 1.07/1.15$ mm
 3. FOR USE WITH BOARD THICKNESS 0.80mm
 4. USE PUNCH AND DIE TOOL PART NUMBER Z2159-00

ORDER CODE:

H2159-XX

FINISH CODE _____

01 - 100% TIN OVER NICKEL

06 - 90/10 TIN/LEAD

SB	4	27.04.17	20490
NAME	ISS.	DATE	C/NOTE
APPROVED:		S.BENNETT	
CHECKED:		M.PLESTED	
DRAWN:		F.PHILIPSON	
CUSTOMER REF.:			
ASSEMBLY DRG:			

HARWIN

www.harwin.com
technical@harwin.com

THIS DRAWING AND ANY INFORMATION OR DESCRIPTIVE MATTER SET OUT HEREON ARE CONFIDENTIAL AND COPYRIGHT PROPERTY OF THE HARWIN GROUP AND MUST NOT BE DISCLOSED, LOANED, COPIED OR USED FOR MANUFACTURING, TENDERING OR FOR ANY OTHER PURPOSE WITHOUT THEIR WRITTEN PERMISSION.

TOLERANCES

~~X = ± 1 mm
X.X = ± 0.50 mm
X.XX = ± 0.10 mm
X.XXX = ± 0.01 mm
ANGLES = $\pm 5^\circ$
UNLESS STATED~~

MATERIAL:

ANNEALED BRASS
CW614N M TO BS EN 12164

FINISH: SEE ABOVE

S/AREA: mm²

TITLE:

TERMINAL

DRAWING NUMBER:

H2159-XX

SHT
2 OF 2